

**2000-CE
MATH
PAPER 2**

MC

HONG KONG EXAMINATIONS AUTHORITY

HONG KONG CERTIFICATE OF EDUCATION EXAMINATION 2000

MATHEMATICS PAPER 2

11.15 am – 12.45 pm (1½ hours)

Subject Code 180

1. Read carefully the instructions on the Answer Sheet and insert the information required (including the Subject Code) in the spaces provided.
2. When told to open this book, check that all the questions are there. Look for the words '**END OF PAPER**' after the last question.
3. **ANSWER ALL QUESTIONS.** All the answers should be marked on the Answer Sheet.
4. Note that you may only mark **ONE** answer to each question. Two or more answers will score **NO MARKS**.
5. All questions carry equal marks. No marks will be deducted for wrong answers.

©香港考試局 保留版權
Hong Kong Examinations Authority
All Rights Reserved 2000

2000-CE-MATH 2-1

FORMULAS FOR REFERENCE

SPHERE	Surface area	$= 4\pi r^2$
	Volume	$= \frac{4}{3}\pi r^3$
CYLINDER	Area of curved surface	$= 2\pi rh$
	Volume	$= \pi r^2 h$
CONE	Area of curved surface	$= \pi rl$
	Volume	$= \frac{1}{3}\pi r^2 h$
PRISM	Volume	$= \text{base area} \times \text{height}$
PYRAMID	Volume	$= \frac{1}{3} \times \text{base area} \times \text{height}$

There are 36 questions in Section A and 18 questions in Section B.
The diagrams in this paper are not necessarily drawn to scale.

Section A

1. If $A = \frac{h}{2}(a+b)$, then $b =$

A. $2A - ah$.

B. $\frac{2}{h}(A - a)$.

C. $\frac{2A - a}{h}$.

D. $a - \frac{2A}{h}$.

E. $\frac{2A}{h} - a$.

2. Factorize $x^2 - x - xy + y$.

A. $(x - y)(x - 1)$

B. $(x - y)(x + 1)$

C. $(x + y)(x - 1)$

D. $(1 - x)(x + y)$

E. $(1 + x)(y - x)$

3. Simplify $\frac{(a^3b^{-1})^{-2}}{(a^{-1}b^2)^4}$.

A. $\frac{1}{ab^3}$

B. $\frac{1}{a^2b^3}$

C. $\frac{1}{a^2b^6}$

D. $\frac{1}{a^2b^9}$

E. $\frac{a^4}{b^6}$

4. Let $f(x) = 3x^2 + ax - 7$. If $f(-1) = 0$, find $f(-2)$.

A. -27

B. -11

C. -3

D. 1

E. 13

5. If $\begin{cases} y = x^2 - 1 \\ y = 2x - 2 \end{cases}$, then $y =$

- A. -4 .
- B. 0 .
- C. 1 .
- D. 0 or 8 .
- E. -4 or 4 .

6. Find the values of x which satisfy both $x + 3 > 0$ and $-2x < 1$.

- A. $x > -3$
- B. $x > -\frac{1}{2}$
- C. $x > \frac{1}{2}$
- D. $-3 < x < -\frac{1}{2}$
- E. $-3 < x < \frac{1}{2}$

7. In the figure, a square of side x cm is cut into 9 equal squares. If the total perimeter of the 9 small squares is 72 cm more than the perimeter of the original square, then $x =$

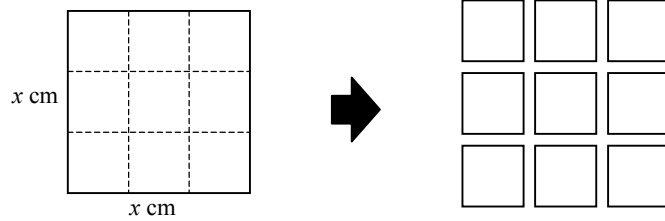

- A. 6 .
 B. 8 .
 C. 9 .
 D. 12 .
 E. 18 .
8. The figure shows a trapezium of area 6 cm^2 . Find x .

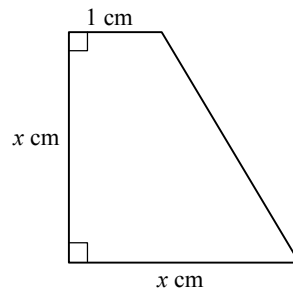

- A. 2
 B. 3
 C. 4
 D. $\sqrt{6}$
 E. $\sqrt{11}$

9. Let $f(x) = x^3 - 2x^2 - 5x + 6$. It is known that $f(1) = 0$. $f(x)$ can be factorized as

- A. $(x-1)^2(x+6)$.
- B. $(x-1)(x+1)(x+6)$.
- C. $(x-1)(x-2)(x+3)$.
- D. $(x-1)(x+2)(x-3)$.
- E. $(x+1)(x-2)(x-3)$.

10. If $3x^2 + ax + 7 \equiv 3(x-2)^2 + b$, then

- A. $a = -12$, $b = -5$.
- B. $a = -12$, $b = 7$.
- C. $a = -4$, $b = 3$.
- D. $a = 0$, $b = -5$.
- E. $a = 0$, $b = 19$.



11. Which of the following may represent the graph of $y = \tan x^\circ$ for $0 \leq x \leq 90$?

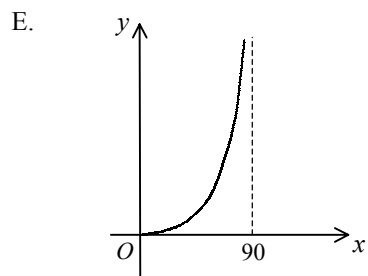
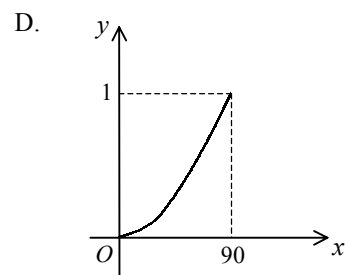
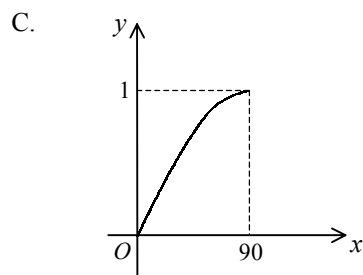
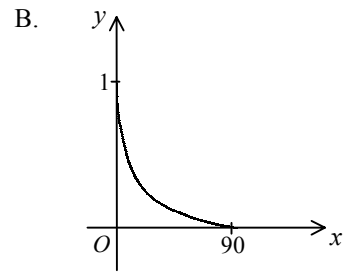
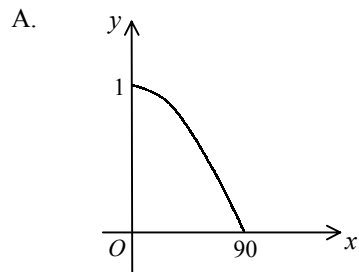

12. In the figure, $ABCD$ is a rectangle formed by four squares each of area 1 cm^2 . DB is a diagonal. Find the area of the shaded region.

A. $\frac{9}{10} \text{ cm}^2$

B. $\frac{7}{8} \text{ cm}^2$

C. $\frac{5}{6} \text{ cm}^2$

D. $\frac{4}{5} \text{ cm}^2$

E. $\frac{3}{4} \text{ cm}^2$

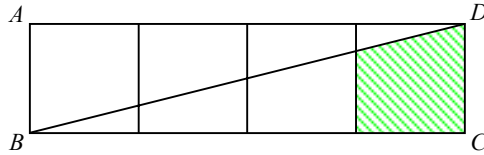

13. In the figure, the areas of the two triangles are equal. Find θ .

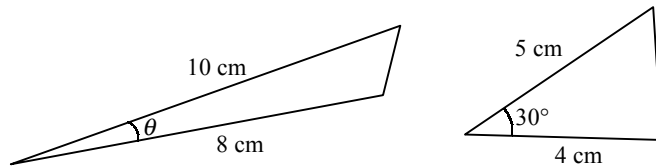

A. 7.2° (correct to the nearest 0.1°)

B. 7.5° (correct to the nearest 0.1°)

C. 14.5° (correct to the nearest 0.1°)

D. 15°

E. 30°

14. A man bought two books at \$30 and \$70 respectively. He sold the first one at a profit of 20% and the second one at a loss of 10%. On the whole, he
- A. lost 1% .
 - B. lost 10% .
 - C. gained 1% .
 - D. gained 10% .
 - E. gained 13% .
15. The 1st and 10th terms of an arithmetic sequence are 2 and 29 respectively. The 20th term of the sequence is
- A. 56 .
 - B. 58 .
 - C. 59 .
 - D. 60 .
 - E. 62 .

16. Which of the following could be a geometric sequence/geometric sequences?

- I. $3, 3^3, 3^5, 3^7, \dots$
- II. $9, 99, 999, 9999, \dots$
- III. $10, -100, 1000, -10000, \dots$

- A. III only
- B. I and II only
- C. I and III only
- D. II and III only
- E. I, II and III

17. In the figure, find the area of $\triangle ABC$.

- A. 12
- B. 15
- C. 16
- D. 20
- E. 25

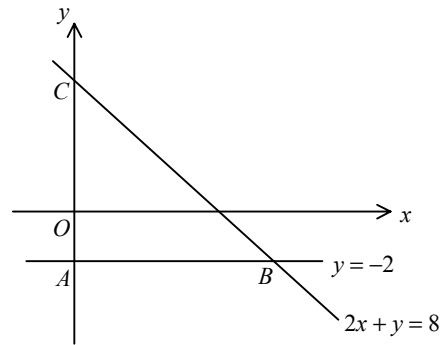

18. Consider the three straight lines

$$L_1 : 6x + 4y - 3 = 0 ,$$

$$L_2 : y = -\frac{3}{2}x + 4 \text{ and}$$

$$L_3 : 6x - 4y + 3 = 0 .$$

Which of the following is/are true?

I. $L_1 \parallel L_2$

II. $L_2 \parallel L_3$

III. $L_1 \perp L_3$

A. I only

B. II only

C. III only

D. I and III only

E. II and III only



19. In the figure, $ABCD$ is a parallelogram. Find $\angle BDE$.

- A. 30°
- B. 35°
- C. 40°
- D. 50°
- E. 55°

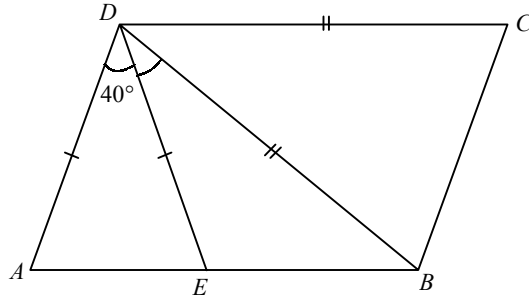

20. In the figure, O is the centre of the circle. $EAOB$ and EDC are straight lines. Find x .

- A. 40°
- B. 46°
- C. 57°
- D. 66°
- E. 68°

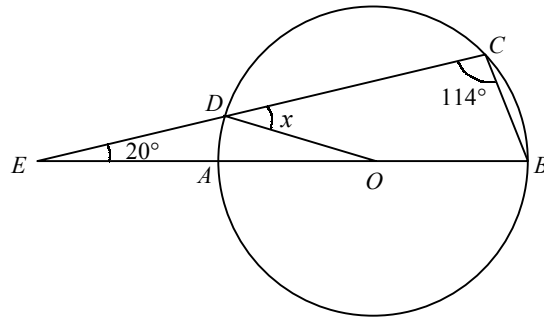

21. Two fair dice are thrown. Find the probability that at least one “6” occurs.

A. $\frac{1}{3}$

B. $\frac{1}{6}$

C. $\frac{5}{18}$

D. $\frac{7}{36}$

E. $\frac{11}{36}$

22. A bag contains six balls which are marked with the numbers -3 , -2 , -1 , 1 , 2 and 3 respectively. Two balls are drawn randomly from the bag. Find the probability that the sum of the numbers drawn is zero.

A. $\frac{1}{30}$

B. $\frac{1}{10}$

C. $\frac{1}{5}$

D. $\frac{1}{3}$

E. $\frac{1}{2}$



23. $\{x, x+2, x+4, x+6, x+8\}$ and $\{x+1, x+3, x+5, x+7, x+9\}$ are two groups of numbers. Which of the following is/are true?

- I. The two groups of numbers have the same range.
- II. The two groups of numbers have the same standard deviation.
- III. The two groups of numbers have the same mean.

- A. I only
- B. II only
- C. III only
- D. I and II only
- E. I and III only

24. In the figure, $AB = CD$, $\angle CAB = \angle ECD$ and $\angle ABC = \angle CDE$. Which of the following must be true?

- I. $\triangle ABC \cong \triangle CDE$
- II. $\triangle ABC \sim \triangle EAC$
- III. EAC is an isosceles triangle

- A. I only
- B. III only
- C. I and II only
- D. I and III only
- E. I, II and III

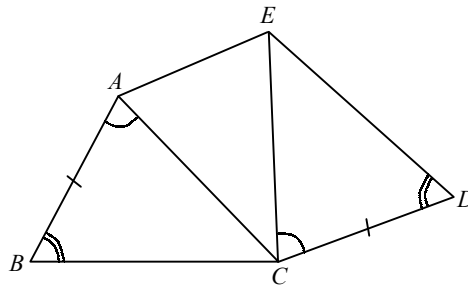

25. In the figure, PXQ , QYR and RZP are semicircles with areas $A_1 \text{ cm}^2$, $A_2 \text{ cm}^2$ and $A_3 \text{ cm}^2$ respectively. If $A_1 = 12$ and $A_2 = 5$, find A_3 .

- A. 13
 B. 17
 C. 169
 D. 13π
 E. $\frac{169}{8}\pi$

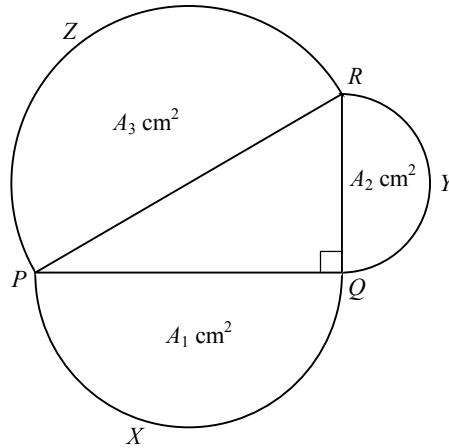

26. In the figure, find the area of the triangle correct to the nearest 0.1 cm^2 .

- A. 7.3 cm^2
 B. 10.7 cm^2
 C. 12.7 cm^2
 D. 15.0 cm^2
 E. 19.1 cm^2

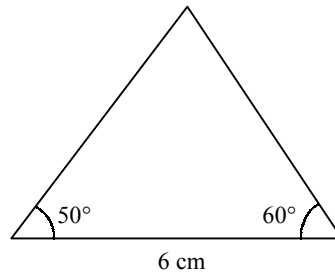

27. In the figure, find x correct to 3 significant figures.

- A. 63.8
- B. 78.5
- C. 84.5
- D. 87.3
- E. 89.1

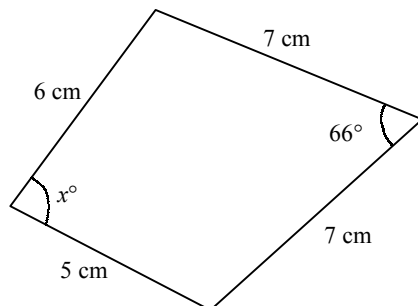

28. In the figure, $ABCD$ is a rectangle. Find CF .

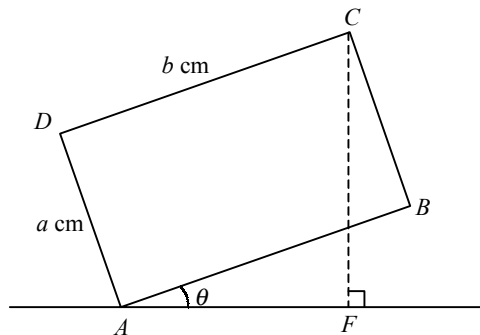

- A. $(a+b)\sin\theta$ cm
- B. $(a+b)\cos\theta$ cm
- C. $(a\sin\theta + b\cos\theta)$ cm
- D. $(a\cos\theta + b\sin\theta)$ cm
- E. $\sqrt{a^2 + b^2} \sin 2\theta$ cm

29. In the figure, DAB is a straight line. $\tan \theta =$

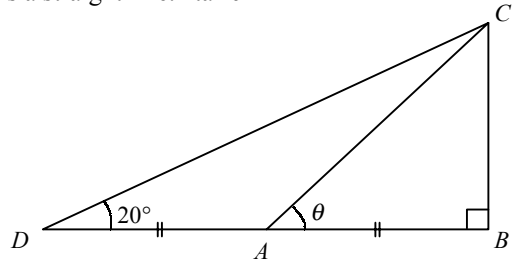

- A. $2 \tan 20^\circ$.
- B. $\frac{1}{2} \tan 20^\circ$.
- C. $\frac{2}{\tan 20^\circ}$.
- D. $\frac{1}{2 \tan 20^\circ}$.
- E. $\tan 40^\circ$.
30. According to the figure, the bearing of B from C is

- A. 050° .
- B. 130° .
- C. 140° .
- D. 310° .
- E. 320° .

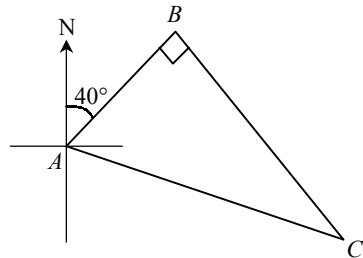

31. In the figure, CAB is a semicircle and $ABCD$ is a parallelogram. Find the area of $ABCD$.

- A. 65 cm^2
- B. 60 cm^2
- C. 52 cm^2
- D. 32.5 cm^2
- E. 30 cm^2

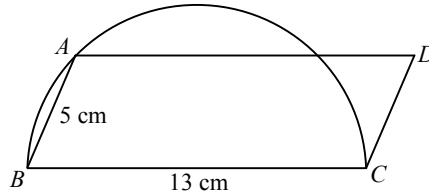

32. The figure shows a square, a triangle and a sector with areas $a \text{ cm}^2$, $b \text{ cm}^2$ and $c \text{ cm}^2$ respectively.

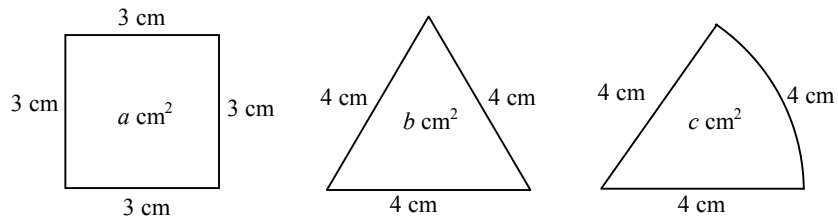

Which of the following is true?

- A. $a > b > c$
- B. $a > c > b$
- C. $b > a > c$
- D. $b > c > a$
- E. $c > a > b$

33. In the figure, a solid wooden sphere of radius r cm is to be cut into a cube of side 3 cm. Find the smallest possible value of r .

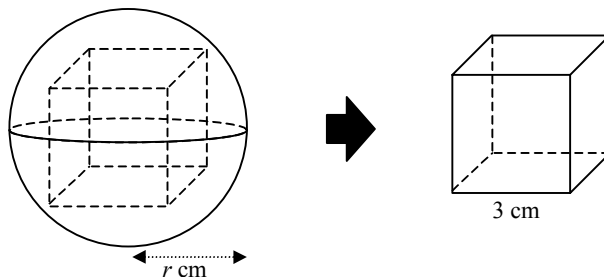

- A. $\frac{3\sqrt{3}}{2}$
- B. $\frac{3\sqrt{2}}{2}$
- C. $\frac{3}{2}$
- D. $3\sqrt{3}$
- E. $3\sqrt{2}$
34. If $9a^2 - b^2 = 0$ and $ab < 0$, then $\frac{a-b}{a+b} =$

- A. -2 .
- B. $-\frac{1}{2}$.
- C. 0 .
- D. $\frac{1}{2}$.
- E. 2 .

35. y varies directly as x^2 and inversely as \sqrt{z} . If $y=1$ when $x=2$ and $z=9$, find y when $x=1$ and $z=4$.

A. $\frac{2}{3}$

B. $\frac{8}{3}$

C. $\frac{1}{6}$

D. $\frac{3}{8}$

E. $\frac{9}{26}$

36. Tea A and tea B are mixed in the ratio $x : y$ by weight. A costs \$80/kg and B costs \$100/kg. If the cost of A is increased by 10% and that of B is decreased by 12%, the cost of the mixture per kg remains unchanged. Find $x : y$.

A. 1 : 1

B. 2 : 3

C. 3 : 2

D. 5 : 6

E. 6 : 5



Section B

37. Simplify $\frac{a}{a+b} + \frac{b}{b-a} + \frac{2ab}{a^2-b^2}$.

A. $\frac{a+b}{a-b}$

B. $-\frac{a-b}{a+b}$

C. $\frac{-a^2+b^2+4ab}{a^2-b^2}$

D. $\frac{a^2+b^2}{a^2-b^2}$

E. 1

38. If $\log(x-a) = 3$, then $x =$

A. 10^{3+a}

B. a^3

C. $1000a$

D. $1000+a$

E. $30+a$



39. Which of the following may represent the graph of $y = -x^2 + 2x - 3$?

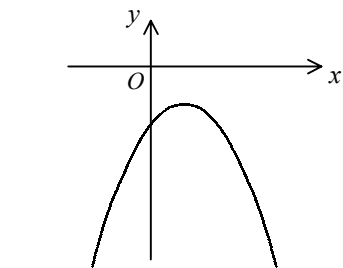
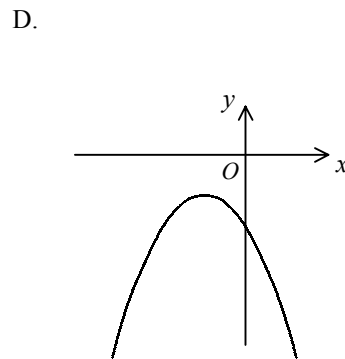
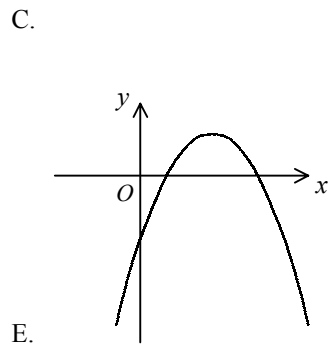
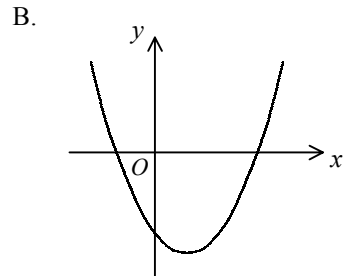
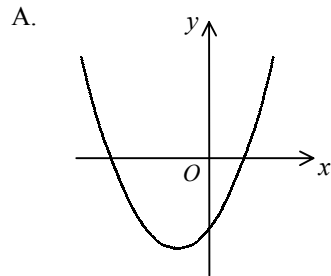

40. If $\left(\frac{\sqrt{5}}{2}+1\right)x = \sqrt{2}$, then $x =$

- A. $2\sqrt{10}-2$.
- B. $2\sqrt{10}-4\sqrt{2}$.
- C. $2\sqrt{10}+4\sqrt{2}$.
- D. $\frac{\sqrt{10}-1}{2}$.
- E. $\frac{2\sqrt{10}-4\sqrt{2}}{3}$.

41. In the figure, the graph of $y = f(x)$ intersects the x -axis at P and Q only. In order to find a root of $f(x) = 0$ using the method of bisection, which of the following intervals can you start with?

- I. $-1 < x < 0$
- II. $-1 < x < 1$
- III. $1 < x < 2$

- A. I only
- B. III only
- C. I and II only
- D. I and III only
- E. I, II and III

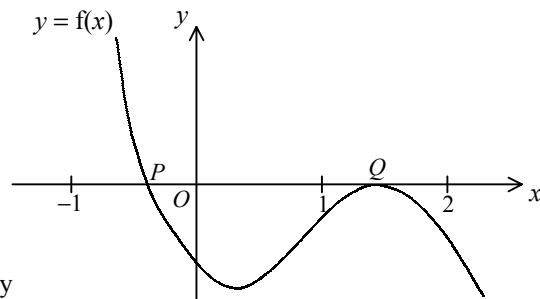

42. According to the figure, which of the following represents the solution of

$$\begin{cases} 0 \leq x \leq 4 \\ x \geq y \\ 0 \leq y \leq 3 \end{cases} ?$$

- A. Region I
 B. Region II
 C. Regions I and VI
 D. Regions II and III
 E. Regions II, III and IV

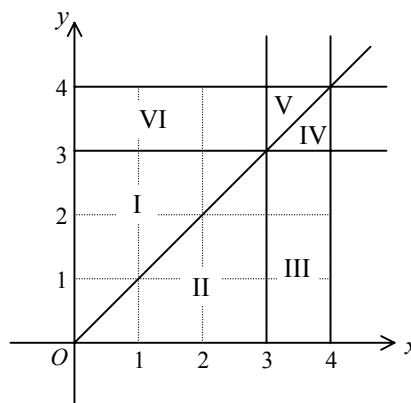

43. In the figure, $ABCDEF$ is a right triangular prism. It is cut into two parts along the plane $PQRS$, which is parallel to the face $BCDF$, and $AP : PB = 2 : 5$. Find $\frac{\text{volume of the prism } APQRES}{\text{volume of the prism } ABCDEF}$.

- A. $\frac{2}{7}$
 B. $\frac{4}{25}$
 C. $\frac{4}{49}$
 D. $\frac{8}{125}$
 E. $\frac{8}{343}$

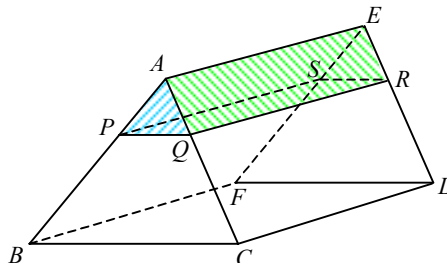

44. π degrees =

- A. $\frac{\pi^2}{180}$ radian .
- B. $\frac{180}{\pi^2}$ radians .
- C. $\frac{\pi}{180}$ radian .
- D. 180 radians .
- E. 1 radian .

45. In the figure, AB is tangent to the circle at B . Find $\angle DCE$.

- A. 70°
- B. 75°
- C. 90°
- D. 95°
- E. 105°

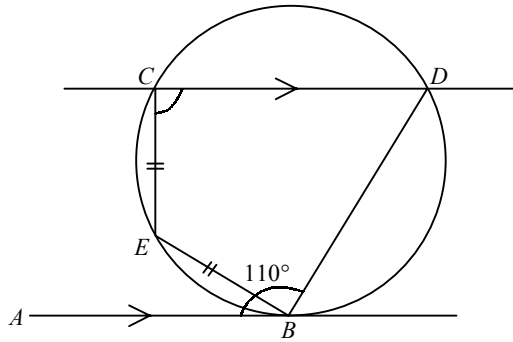

46. In the figure, $\widehat{AB} : \widehat{BC} : \widehat{CD} = 2 : 1 : 3$. Find $\angle ADC$.

- A. 56°
- B. 60°
- C. 63°
- D. 72°
- E. 84°

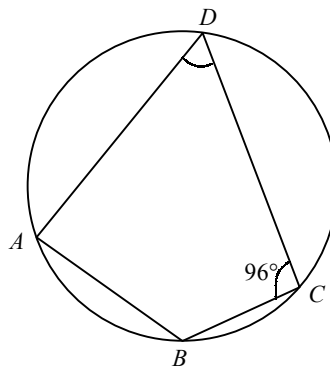

47. The bar chart below shows the distribution of scores of a test. Find the mean deviation of the scores of the test.

- A. 0 mark
- B. $\frac{8}{9}$ mark
- C. $\frac{2\sqrt{2}}{3}$ mark
- D. $\frac{2\sqrt{3}}{3}$ marks
- E. $\frac{6}{5}$ marks

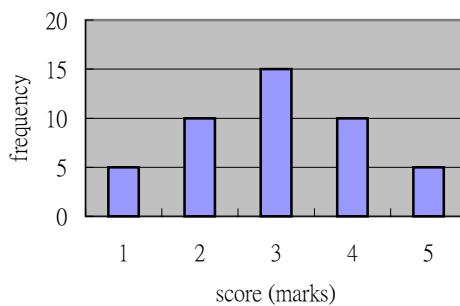

48. If the centre of the circle $x^2 + y^2 + kx + (k+1)y - 3 = 0$ lies on $x + y + 1 = 0$, find k .

A. $\frac{3}{2}$

B. $\frac{1}{2}$

C. 0

D. -1

E. $-\frac{3}{2}$

49. If the straight line $y = mx + 1$ is tangent to the circle $(x-2)^2 + y^2 = 1$, then $m =$

A. $-\frac{4}{3}$.

B. 0.

C. $\frac{4}{3}$.

D. 0 or $-\frac{4}{3}$.

E. 0 or $\frac{4}{3}$.

50. $A(-1, -4)$ and $B(3, 4)$ are two points. The line $x - y = 0$ cuts AB at P so that $AP : PB = r : 1$. Find r .

A. 3

B. 2

C. 1

D. $\frac{1}{2}$

E. $\frac{1}{3}$

51. If $\cos \theta = \frac{1}{k}$ and $0^\circ < \theta < 90^\circ$, then $\tan(\theta - 270^\circ) =$

A. $-\frac{k}{\sqrt{1-k^2}}$.

B. $-\frac{1}{\sqrt{k^2-1}}$.

C. $\frac{1}{\sqrt{k^2-1}}$.

D. $-\sqrt{k^2-1}$.

E. $\sqrt{k^2-1}$.

52. The figure shows a right triangular prism. Find its volume.

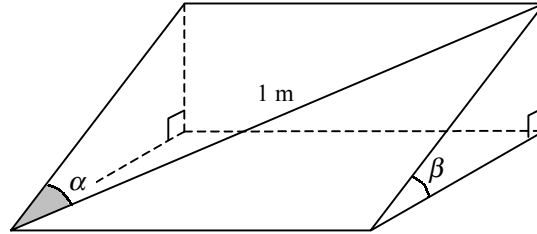

- A. $\frac{1}{3} \sin^2 \alpha \cos \alpha \sin \beta \cos \beta \text{ m}^3$
- B. $\frac{1}{3} \sin \alpha \cos^2 \alpha \sin \beta \cos \beta \text{ m}^3$
- C. $\frac{1}{2} \sin \alpha \cos \alpha \sin \beta \cos \beta \text{ m}^3$
- D. $\frac{1}{2} \sin^2 \alpha \cos \alpha \sin \beta \cos \beta \text{ m}^3$
- E. $\frac{1}{2} \sin \alpha \cos^2 \alpha \sin \beta \cos \beta \text{ m}^3$

53. In the figure, the area of $\triangle ABC$ is

- A. $\frac{\pi}{3}$.
- B. $\frac{2\pi}{3}$.
- C. π .
- D. $\frac{4\pi}{3}$.
- E. 2π .

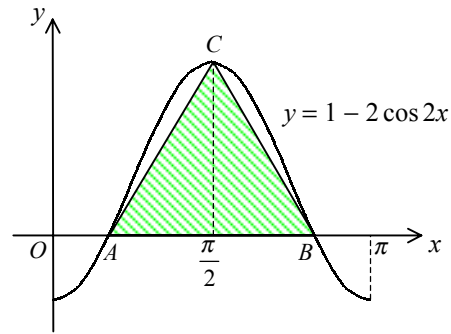

54. In the figure, AEC and BED are straight lines. If the area of $\triangle ABE = 4 \text{ cm}^2$ and the area of $\triangle BCE = 5 \text{ cm}^2$, find the area of $\triangle CDE$.

- A. 4.5 cm^2
- B. 5 cm^2
- C. 6 cm^2
- D. 6.25 cm^2
- E. 9 cm^2

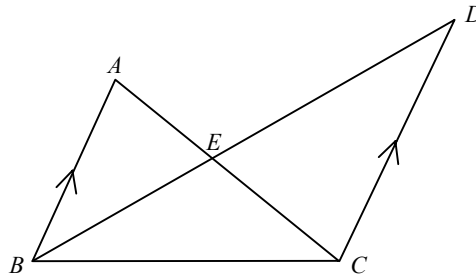

END OF PAPER

2000 Mathematics (Paper 2)

Question No.	Key	Question No.	Key
1.	E	31.	B
2.	A	32.	B
3.	C	33.	A
4.	E	34.	A
5.	B	35.	D
6.	B	36.	C
7.	C	37.	E
8.	B	38.	D
9.	D	39.	E
10.	A	40.	B
11.	E	41.	C
12.	B	42.	D
13.	A	43.	C
14.	A	44.	A
15.	C	45.	E
16.	C	46.	C
17.	E	47.	B
18.	A	48.	B
19.	A	49.	D
20.	E	50.	A
21.	E	51.	B
22.	C	52.	E
23.	D	53.	C
24.	D	54.	D
25.	B		
26.	C		
27.	D		
28.	D		
29.	A		
30.	D		