

**99-CE
MATHS**
Paper2

MC

HONG KONG EXAMINATIONS AUTHORITY
HONG KONG CERTIFICATE OF EDUCATION EXAMINATION 1999

MATHEMATICS PAPER 2

11.15 am – 12.45 pm (1½ hours)

Subject Code 180

1. Read carefully the instructions on the Answer Sheet and insert the information required (including the Subject Code) in the spaces provided.
2. When told to open this book, check that all the questions are there. Look for the words '**END OF PAPER**' after the last question.
3. **ANSWER ALL QUESTIONS.** All the answers should be marked on the Answer Sheet.
4. Note that you may only mark **ONE** answer to each question. Two or more answers will score **NO MARKS**.
5. All questions carry equal marks. No marks will be deducted for wrong answers.

©香港考試局 保留版權
Hong Kong Examinations Authority
All Rights Reserved 1999

99-CE-MATHS 2-1

FORMULAS FOR REFERENCE

SPHERE	Surface area	$= 4\pi r^2$
	Volume	$= \frac{4}{3}\pi r^3$
CYLINDER	Area of curved surface	$= 2\pi rh$
	Volume	$= \pi r^2 h$
CONE	Area of curved surface	$= \pi rl$
	Volume	$= \frac{1}{3}\pi r^2 h$
PRISM	Volume	$= \text{base area} \times \text{height}$
PYRAMID	Volume	$= \frac{1}{3} \times \text{base area} \times \text{height}$

**There are 36 questions in Section A and 18 questions in Section B.
The diagrams in this paper are not necessarily drawn to scale.**

Section A

1. If $f(x) = x^2 - 1$, then $f(a-1) =$

A. $a^2 - 2a$.

B. $a^2 - 3a$.

C. $a^2 - 3a - 2$.

D. $a^2 - 1$.

E. $a^2 - 2$.

2. $x^2 - y^2 - x + y =$

A. $(x - y)(x - y - 1)$.

B. $(x - y)(x + y - 1)$.

C. $(x - y)(x + y + 1)$.

D. $(x + y)(x - y - 1)$.

E. $(x + y)(x - y + 1)$.

3. If $a = \frac{1+b}{1-b}$, then $b =$

A. $\frac{a-1}{2}$.

B. $\frac{a-1}{2a}$.

C. $\frac{a+1}{a-1}$.

D. $\frac{a-1}{a+1}$.

E. $\frac{1-a}{a+1}$.

4. If $4^x = a$, then $16^x =$

A. $4a$.

B. a^2 .

C. a^4 .

D. 2^a .

E. 4^a .

5. In the figure, the graph of $y = x^2 - 6x + k$ touches the x -axis. Find k .

- A. $k \geq 0$
- B. $k \geq 9$
- C. $k = -9$
- D. $k = 0$
- E. $k = 9$

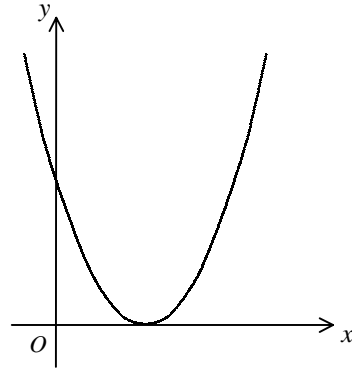

6. If $(3x-1)(x-a) \equiv 3x^2 + bx - 2$, then

- A. $a = 2, b = -1$.
- B. $a = 2, b = -7$.
- C. $a = -2, b = 5$.
- D. $a = -2, b = -5$.
- E. $a = -2, b = -7$.

7. Solve $x^2 + 10x - 24 > 0$.
- A. $x < -12$ or $x > 2$
 - B. $x < -6$ or $x > -4$
 - C. $x < -2$ or $x > 12$
 - D. $-12 < x < 2$
 - E. $-2 < x < 12$

8. If $\begin{cases} y = x^2 + 3x - 2 \\ y = -x + 3 \end{cases}$, then
- A. $x = -1$.
 - B. $x = -1$ or 5 .
 - C. $x = -2$ or 1 .
 - D. $x = -5$ or 1 .
 - E. $x = -5$ or 8 .

9. Which of the following may represent the graph of $y = x^2 - 3x - 18$?

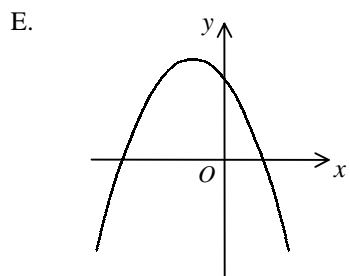
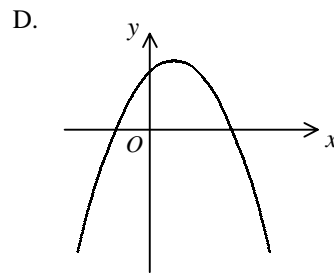
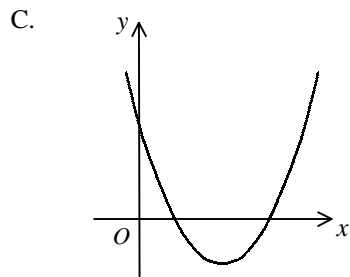
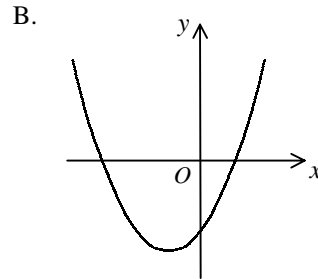
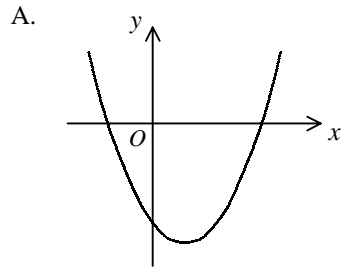

10. The n -th term of an arithmetic sequence is $2 + 5n$. Find the sum of the first 100 terms of the sequence.
- A. 502
 - B. 12450
 - C. 25200
 - D. 25450
 - E. 25700
11. In a class, students study either History or Geography, but not both. If the number of students studying Geography is 50% more than those studying History, what is the percentage of students studying History?
- A. 25%
 - B. $33\frac{1}{3}\%$
 - C. 40%
 - D. 60%
 - E. $66\frac{2}{3}\%$

12. If $x:y = 3:4$ and $2x+5y = 598$, find x .
- A. 23
 - B. 26
 - C. 69
 - D. 78
 - E. 104
13. If 1 Australian dollar is equivalent to 4.69 H.K. dollars and 100 Japanese yen are equivalent to 5.35 H.K. dollars, how many Japanese yen are equivalent to 1 Australian dollar? Give your answer correct to the nearest Japanese yen.
- A. 4
 - B. 25
 - C. 88
 - D. 114
 - E. 2509

14. Let m be a positive integer. Which of the following must be true?

- I. m^2 is even.
 - II. $m(m+1)$ is even.
 - III. $m(m+2)$ is even.
- A. I only
 - B. II only
 - C. III only
 - D. I and III only
 - E. II and III only

15. In the figure, the bearing of B from C is

- A. $N5^\circ E$.
- B. $N65^\circ E$.
- C. $N85^\circ E$.
- D. $S5^\circ W$.
- E. $S85^\circ W$.

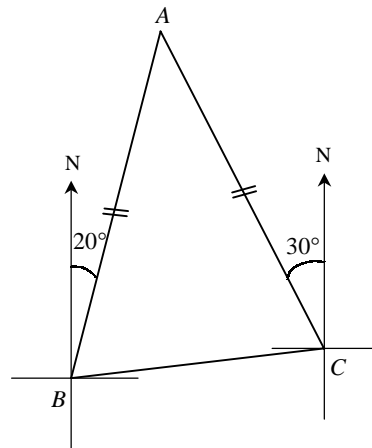

16. Which of the following may represent the graph of $y = \cos x^\circ$ for $0 \leq x \leq 90$?

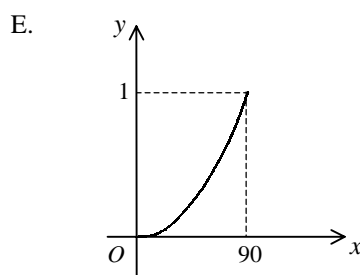
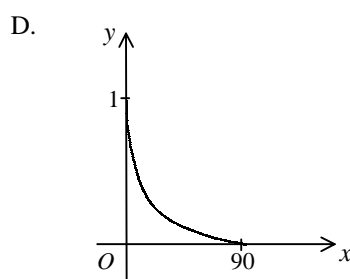
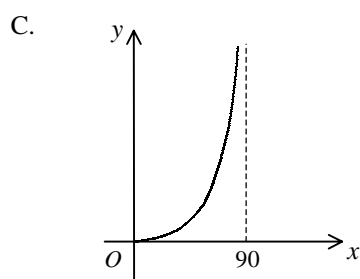
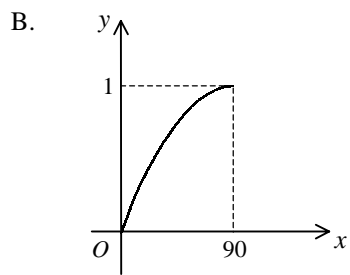
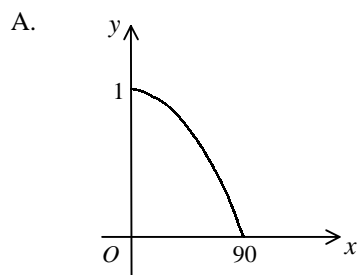

17. In the figure, find x correct to 3 significant figures.

- A. 1.28
- B. 1.29
- C. 1.35
- D. 1.53
- E. 1.65

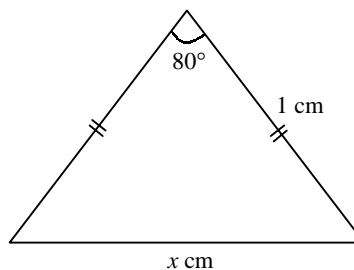

18. In the figure, $\frac{AC}{AB} =$

- A. $\frac{4}{3}$.
- B. $\frac{5}{4}$.
- C. $\frac{\sqrt{2}}{2}$.
- D. $\frac{\sqrt{6}}{2}$.
- E. $\frac{\sqrt{6}}{3}$.

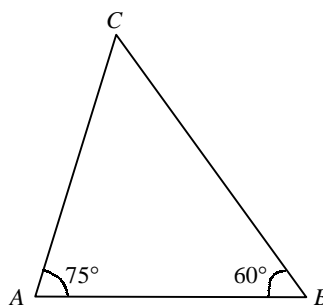

19. In the figure, find x correct to 1 decimal place.

- A. 15.0
- B. 18.4
- C. 22.5
- D. 24.1
- E. 26.6

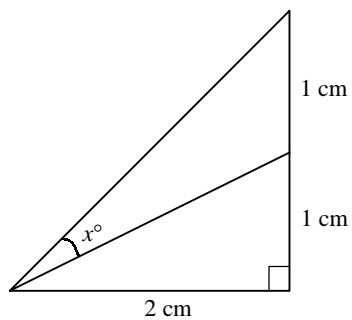

20. In the figure, $ABCD$ is a parallelogram. Find $\angle ABC$ correct to the nearest degree.

- A. 83°
- B. 97°
- C. 104°
- D. 124°
- E. 139°

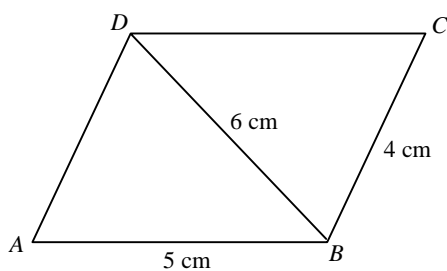

21. In the figure, a square is inscribed in a circle with radius 1 cm . Find the area of the shaded region.

- A. $(\pi - 2) \text{ cm}^2$
 B. $(\pi - \sqrt{2}) \text{ cm}^2$
 C. $(\pi - 1) \text{ cm}^2$
 D. $(2\pi - 2) \text{ cm}^2$
 E. $(2\pi - 1) \text{ cm}^2$

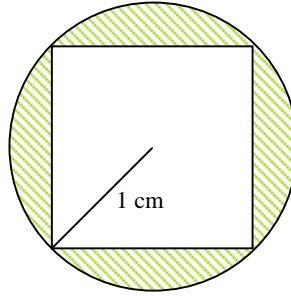

22. The figure shows a right prism. Find its total surface area.

- A. 104 cm^2
 B. 108 cm^2
 C. 114 cm^2
 D. 120 cm^2
 E. 140 cm^2

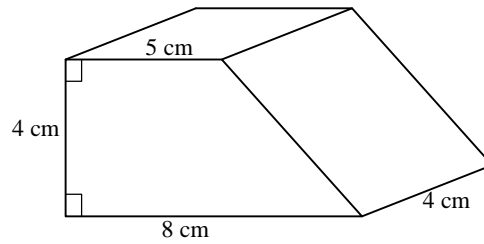

23. In the figure, a cylindrical vessel of internal diameter 6 cm contains some water. A steel ball of radius 2 cm is completely submerged in the water. Find the rise in the water level.

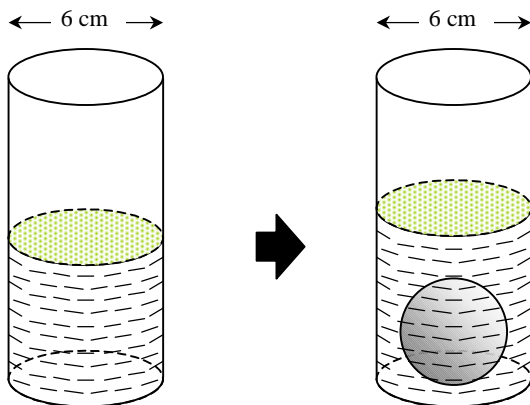

- A. $\frac{32}{27}$ cm
B. $\frac{8}{27}$ cm
C. $\frac{16}{9}$ cm
D. $\frac{4}{9}$ cm
E. $\frac{8}{3}$ cm

24. In the figure, the solid consists of a right circular cone and a hemisphere with a common base. Find the volume of the solid.

- A. $30\pi \text{ cm}^3$
- B. $33\pi \text{ cm}^3$
- C. $48\pi \text{ cm}^3$
- D. $54\pi \text{ cm}^3$
- E. $72\pi \text{ cm}^3$

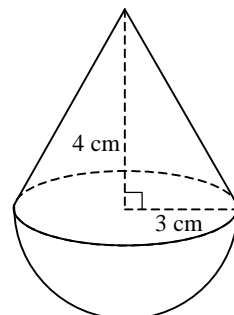

25. In the figure, $ABCD$ is a semicircle. Find the area of the shaded region correct to the nearest 0.01 cm^2 .

- A. 5.33 cm^2
- B. 2.87 cm^2
- C. 2.67 cm^2
- D. 1.33 cm^2
- E. 0.17 cm^2

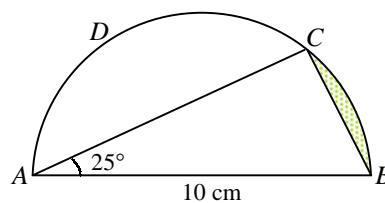

26. In the figure, O is the centre of the circle. Find x .

- A. 12°
- B. 20°
- C. 24°
- D. 40°
- E. 60°

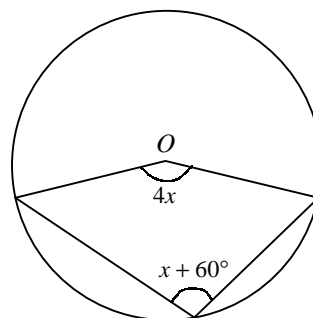

27. In the figure, AB is a diameter of the circle. Find x .

- A. 26°
- B. 32°
- C. 38°
- D. 52°
- E. 64°

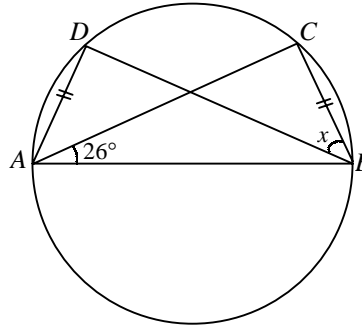

28. In the figure, ACD and ECB are straight lines. If $\angle EAC = \angle CAB$ and $EA = EB$, find x .

- A. 22°
- B. 34°
- C. 44°
- D. 46°
- E. 68°

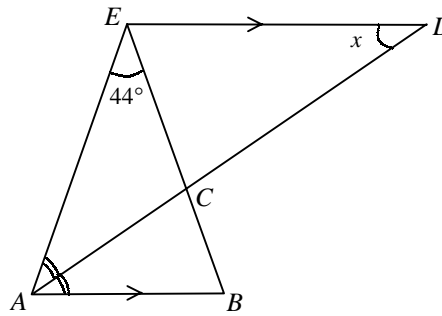

29. In the figure, $ABCDE$ is a regular pentagon and $ABFG$ is a square. Find x .

- A. 18°
 B. 27°
 C. 30°
 D. 36°
 E. 45°

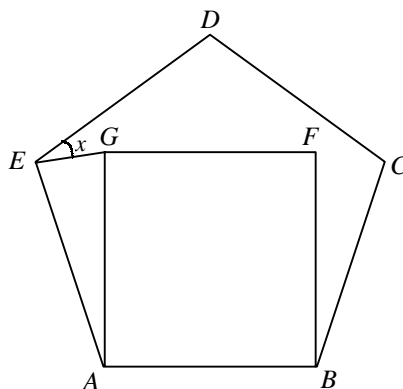

30. In the figure, AEB and ADC are straight lines. Find ED .

- A. $\frac{10}{3}$ cm
 B. $\frac{40}{13}$ cm
 C. 3 cm
 D. $\sqrt{40}$ cm
 E. $\sqrt{80}$ cm

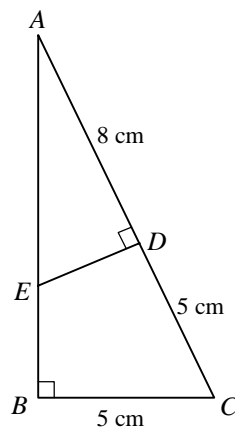

31. $A(-4, 2)$ and $B(1, -3)$ are two points. C is a point on the y -axis such that $AC = CB$. Find the coordinates of C .

- A. $(-\frac{3}{2}, -\frac{1}{2})$
- B. $(-1, 0)$
- C. $(1, 0)$
- D. $(0, -1)$
- E. $(0, 1)$

32. In the figure, $OABC$ is a parallelogram. If the equation of OC is $2x - y = 0$ and the length of CB is 3, find the equation of AB .

- A. $x - 2y - 3 = 0$
- B. $2x - y - 3 = 0$
- C. $2x - y + 3 = 0$
- D. $2x - y - 6 = 0$
- E. $2x - y + 6 = 0$

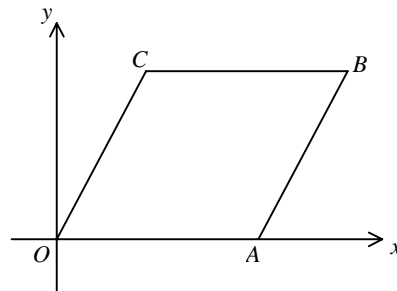

33. Find the median and mode of the ten numbers
6, 8, 3, 3, 5, 5, 5, 7, 7, 11.
- A. median = 5, mode = 5
 - B. median = 5, mode = 5.5
 - C. median = 5.5, mode = 5
 - D. median = 5.5, mode = 6
 - E. median = 6, mode = 5
34. A student scored 50 marks in a test and the corresponding standard score is -0.5 . If the mean of the test scores is 60 marks, find the standard deviation of the scores.
- A. $\sqrt{20}$ marks
 - B. 5 marks
 - C. 9.5 marks
 - D. 10 marks
 - E. 20 marks

35. Two cards are drawn randomly from four cards numbered 1, 2, 3 and 4 respectively. Find the probability that the sum of the numbers drawn is odd.

A. $\frac{1}{6}$

B. $\frac{1}{4}$

C. $\frac{1}{3}$

D. $\frac{1}{2}$

E. $\frac{2}{3}$

36. Tom and Mary each throws a dart. The probability of Tom's dart hitting the target is $\frac{1}{3}$ while that of Mary's is $\frac{2}{5}$. Find the probability of only one dart hitting the target.

A. $\frac{2}{15}$

B. $\frac{3}{15}$

C. $\frac{7}{15}$

D. $\frac{11}{15}$

E. $\frac{13}{15}$

Section B

37. In the figure, a right circular cone is divided into two parts X and Y by a plane parallel to the base such that the lengths of their slant edges are 4 cm and 3 cm respectively. Find the ratio of the curved surface areas of X and Y .

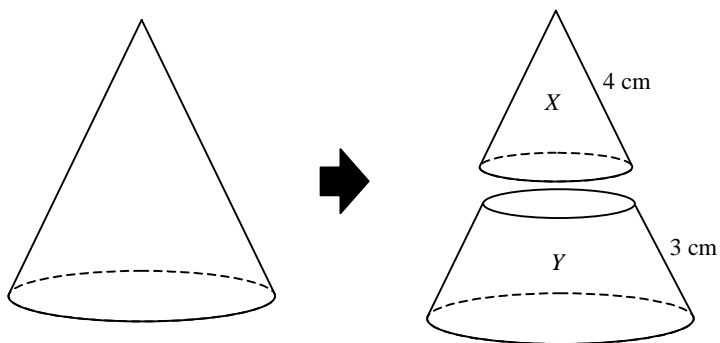

- A. 16 : 9
B. 16 : 33
C. 16 : 49
D. 64 : 27
E. 64 : 279
38. It is given that $F(x) = x^3 - 4x^2 + ax + b$. $F(x)$ is divisible by $x - 1$. When it is divided by $x + 1$, the remainder is 12. Find a and b .
- A. $a = 5, b = 10$
B. $a = 1, b = 2$
C. $a = -3, b = 6$
D. $a = -4, b = 7$
E. $a = -7, b = 10$

39. If $\frac{1}{2} \log y = 1 + \log x$, then

A. $y = \sqrt{10x}$.

B. $y = 100 + x^2$.

C. $y = (10 + x)^2$.

D. $y = 10x^2$.

E. $y = 100x^2$.

40. $\frac{2}{x^2 - 1} - \frac{x - 1}{x^2 - 2x - 3} =$

A. $\frac{-x^2 + 2x + 5}{(x - 1)(x + 1)(x + 3)}$.

B. $\frac{-x^2 + 2x + 7}{(x - 1)(x + 1)(x + 3)}$.

C. $\frac{-x^2 - 5}{(x - 3)(x - 1)(x + 1)}$.

D. $\frac{x^2 - 5}{(x - 3)(x - 1)(x + 1)}$.

E. $\frac{-x^2 + 4x - 7}{(x - 3)(x - 1)(x + 1)}$.

41. The method of bisection is used to find the root of $\sin x + x - 1 = 0$ starting with the interval $[0, 2]$. After the first approximation, the interval which contains the root becomes $[0, 1]$. Find the interval which contains the root after the third approximation.
- A. $[0, 0.25]$
 B. $[0.25, 0.75]$
 C. $[0.5, 0.75]$
 D. $[0.5, 1]$
 E. $[0.75, 1]$
42. John goes to school and returns home at speeds x km/h and $(x + 1)$ km/h respectively. The school is 2 km from John's home and the total time for the two journeys is 54 minutes. Which of the following equations can be used to find x ?
- A. $\frac{x}{2} + \frac{x+1}{2} = \frac{54}{60}$
 B. $\frac{2}{x} + \frac{2}{x+1} = \frac{54}{60}$
 C. $\frac{\frac{1}{2}[x+(x+1)]}{4} = \frac{54}{60}$
 D. $\frac{4}{\frac{1}{2}[x+(x+1)]} = \frac{54}{60}$
 E. $2x + 2(x+1) = \frac{54}{60}$

43. In the figure, find the point (x, y) in the shaded region (including the boundary) at which $bx - ay + 3$ attains its greatest value.

- A. $(0, 0)$
- B. $(-a, b)$
- C. (a, b)
- D. $(b, -a)$
- E. (b, a)

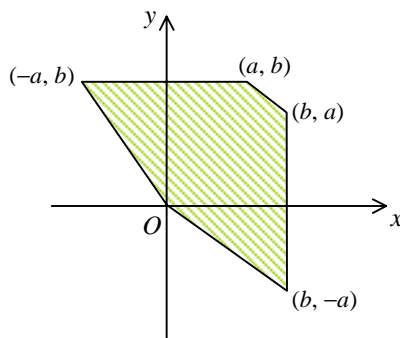

44. The sum of the first two terms of a geometric sequence is 3 and the sum to infinity of the sequence is 4. Find the common ratio of the sequence.

- A. $-\frac{1}{7}$
- B. $\frac{1}{7}$
- C. $\frac{1}{4}$
- D. $-\frac{1}{2}$
- E. $-\frac{1}{2}$ or $\frac{1}{2}$

45. It is given that y varies inversely as x^3 . If x is increased by 100%, then y is

- A. increased by 800% .
- B. increased by 700% .
- C. decreased by 300% .
- D. decreased by 87.5% .
- E. decreased by 12.5% .

46.
$$\frac{\cos(90^\circ - A) \cos(-A)}{\sin(360^\circ - A)} =$$

- A. $-\cos A$.
- B. $\cos A$.
- C. $\sin A$.
- D. $-\frac{\cos^2 A}{\sin A}$.
- E. $\frac{\cos^2 A}{\sin A}$.

47. If $0 \leq \theta \leq 2\pi$, solve $(\cos \theta - 3)(3 \sin \theta - 2) = 0$ correct to 3 significant figures.

- A. 0.730 or 1.23
- B. 0.730 or 2.41
- C. 0.730 or 3.87
- D. 0.730 or 6.21
- E. 0.734 or 2.41

48. The figure shows five sectors. Which of the marked angles measures 2 radians?

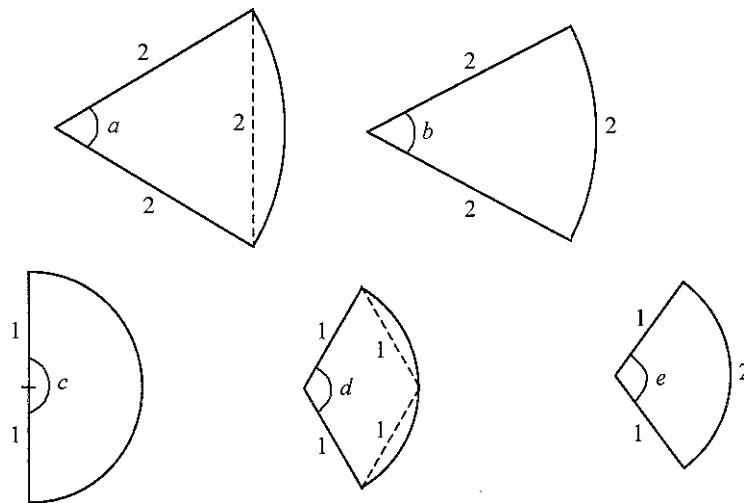

- A. a
 B. b
 C. c
 D. d
 E. e

49. In the figure, $ABCDEFGH$ is a rectangular block. Find the inclination of EM to the plane $ABCD$ correct to the nearest degree.

- A. 23°
 B. 25°
 C. 65°
 D. 71°
 E. 75°

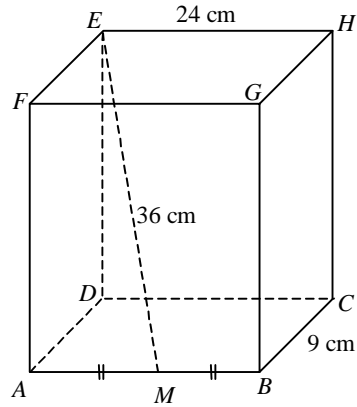

50. In the figure, AT is tangent to the circle at T and ABC is a straight line. Find AT .

- A. 9 cm
 B. 12 cm
 C. 15 cm
 D. 16 cm
 E. 20 cm

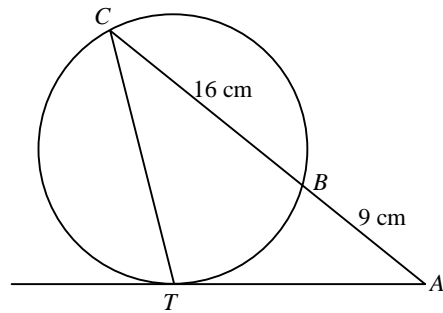

51. In the figure, find the equation of the circle with AB as a diameter.

A. $x^2 + y^2 - 2x + 2y - 23 = 0$

B. $x^2 + y^2 - 2x + 2y - 3 = 0$

C. $x^2 + y^2 + 2x - 2y - 23 = 0$

D. $x^2 + y^2 + 2x - 2y - 3 = 0$

E. $x^2 + y^2 - 25 = 0$

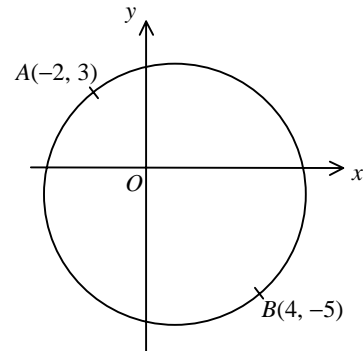

52. The figure shows a circle centred at C and passing through $O(0, 0)$, $A(6, 0)$ and $B(0, 8)$. Which of the following must be true?

I. C lies on the line $\frac{x}{6} + \frac{y}{8} = 1$.

II. The radius of the circle is 10.

III. OC is perpendicular to AB .

A. I only

B. II only

C. I and II only

D. I and III only

E. I, II and III

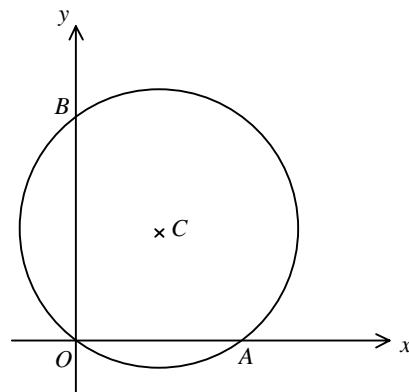

53. Two circles with equations $(x+1)^2 + (y+1)^2 = 25$ and $(x-11)^2 + (y-8)^2 = 100$ touch each other externally at a point P . Find the coordinates of P .

- A. $(-3, -2)$
- B. $(\frac{7}{5}, \frac{4}{5})$
- C. $(3, 2)$
- D. $(5, \frac{7}{2})$
- E. $(7, 5)$

54. In the figure, $ABCD$ is a rectangle. M is the midpoint of BC and AC intersects MD at N .
Area of $\triangle NCD$: area of $\triangle BMN$ =

- A. $1 : 2$.
- B. $1 : 3$.
- C. $2 : 3$.
- D. $2 : 5$.
- E. $4 : 7$.

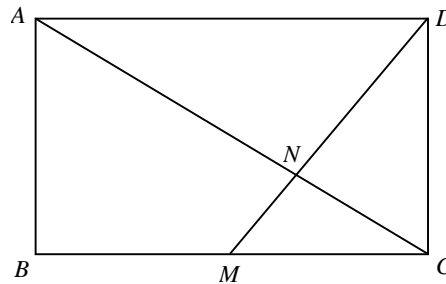

END OF PAPER

1999 Mathematics (Paper 2)

Question No.	Key	Question No.	Key
1.	A	31.	E
2.	B	32.	D
3.	D	33.	C
4.	B	34.	E
5.	E	35.	E
6.	C	36.	C
7.	A	37.	B
8.	D	38.	E
9.	A	39.	E
10.	D	40.	E
11.	C	41.	C
12.	C	42.	B
13.	C	43.	D
14.	B	44.	E
15.	E	45.	D
16.	A	46.	A
17.	B	47.	B
18.	D	48.	E
19.	B	49.	C
20.	B	50.	C
21.	A	51.	A
22.	E	52.	A
23.	A	53.	C
24.	A	54.	D
25.	D		
26.	D		
27.	C		
28.	B		
29.	B		
30.	A		